

SureBead® Reduced Cavity Dispensing Guns



SureBead guns and modules maximize application flexibility, produce clean patterns and deliver sharp cutoff.

SureBead guns and modules:

- Deliver reliable and long-life operation
- Use removable, reduced cavity Saturn®-style nozzles
- Feature new* EasyOn™ design for faster installation

Color-coding identifies AO/AC or AO/SC actuation

“Cool to touch” module cover increases protection during incidental contact

Inspection port allows visual monitoring of module performance

Removable, reduced cavity nozzle allows quick and efficient bead size changes

Myritex™ seals extend module life

Large diameter heater improves service life

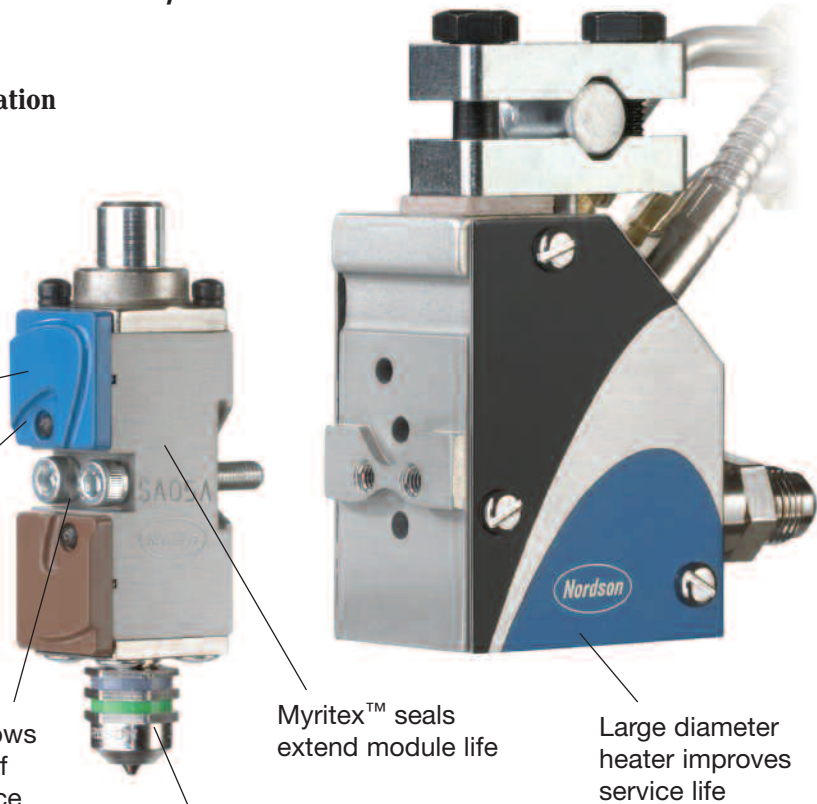

SureBead reduced cavity guns and modules produce high quality patterns with virtually clog-free operation. Modules feature needle and seat design and are smaller than previous SureBead models for better placement in machines. SureBead A features air-open/air-close (AO/AC) and SureBead S features air-open/spring-closed (AO/SC) actuation.

Gun modules are fully rebuildable and key gun body components are easily accessible for easier, faster maintenance. All single and multi-module guns are built from the same gun body platform for greater application flexibility and system compatibility. The new Best Choice™ configurator allows you to quickly and easily determine the right gun body for your application, minimizing the need for specially engineered guns and reducing delivery time.

SureBead nozzles are similar in design to Nordson Saturn® nozzles, with gray upper ring to indicate a pressed-in seat with minimal engagement and a color-coded lower ring to indicate orifice size. The self-cleaning action of the integrated nozzle and needle assembly produces clean patterns and sharp cutoff.

Unique EasyOn module mounting provides:

- Guided, one-way fit (mated module and gun body surfaces)
- Easier, safer installation (especially on gun bodies located deep within machines)
- Backward compatibility (modules fit existing Nordson gun bodies)
- Simpler design

* Patent applied for

**Dual rings are a trademark of Nordson Corporation



The EasyOn mark is your assurance of genuine Nordson quality.

SureBead® Reduced Cavity Guns and Modules

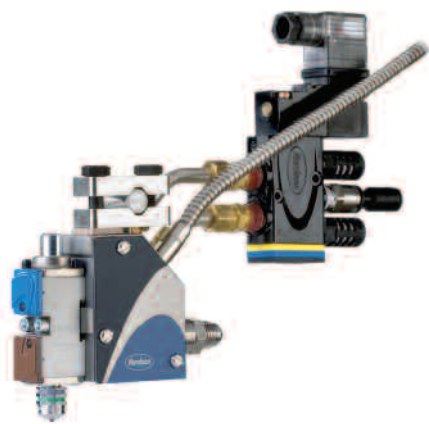

SureBead A guns are shipped with Nordson Saturn® solenoid valves to optimize gun performance.

Color-coded plastic module covers provide easy identification of AO/AC (blue) or AO/SC (black) characteristics; brown color indicates needle/seat design.

EasyOn “mated” module and gun body surfaces speed installation and maintenance.

Specifications

Operating Temperature	450° F (230° C) maximum
Operating Air Pressure¹	45 to 80 psi (3.1 to 5.5 bar)
Working Hydraulic Pressure	1500 psi (103 bar) maximum
Operating Speed	Exceeds 3500 cycles per minute
Precision Nozzles²	Single; selected nozzle comes mounted on module
Saturn® Solenoid Valves³	Nordson 24 VDC Saturn high-temperature solenoids recommended
Electrical Service	240 VAC, 50/60 Hz 200 VAC, 50/60 Hz optional

Notes:

¹ Recommended range. Dry, regulated, unlubricated air required for consistent gun operation.

² Optional SureBead nozzle/orifice diameters and centerline spacings are available.

³ Nordson specifies 24 VDC Saturn high-temperature valves for pattern accuracy and extended service life.

Dimensions

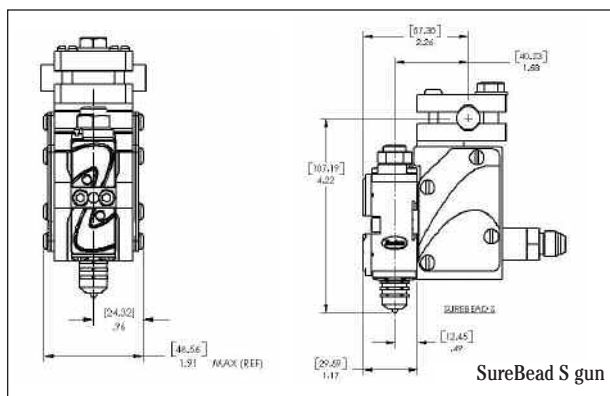
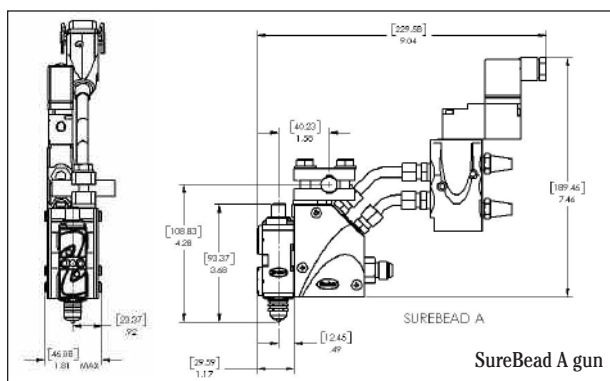

For more information, talk with your Nordson representative or contact your Nordson regional office.

United States

Duluth, Georgia
Telephone: (800) 683-2314
Facsimile: (866) 667-3329

Canada

Markham, Ontario
Telephone: (800) 463-3200
Facsimile: (905) 475-8821

Europe

Lüneburg, Germany
Telephone: (49) 4131-894-0
Facsimile: (49) 4131-894-149

Japan

Tokyo, Japan
Telephone: (81) 3-5762-2700
Facsimile: (81) 3-5762-2701

Asia/Australia/ Latin America

Amherst, Ohio
Telephone: (440) 985-4797
Facsimile: (440) 985-1096

www.nordson.com



When you expect more.®